



KIA Genuine Accessories

Vehicle Model	Sorento LX & EX	Accessory	Side Step
Model Year	2014~	Difficulty	(B)
Part No.	2PF37 AC700		

Note: Difficulty stated above reflects the minimum level of expertise required to install the accessory
 (A) Customer (B) Dealer Technician (C) Master Technician

Instructional Symbols / Definitions

	Denotes warnings that may lead to serious physical injury or vehicle damage.		Denotes quality processes to be checked prior to moving to the next step.	Denotes safety equipment required to be used such as a mask, goggles, rubber gloves, and hearing protection.	
	Denotes cautions to be taken to avoid physical injury or electronic component damage.		Denotes specific tools that are necessary to complete the step.		
	Denotes cautions to be taken to avoid vehicle and component damage.	N O T E	Denotes instructional steps necessary to complete the process.		
				Mask	Goggles
				Rubber Gloves	Hearing Protection

Basic Required Hand Tools

Phillips Head Screwdriver	Phillips Right Angle Driver	Power Drill	Drill-Bit (3mm, 1/8")	Clean Cloth	50/50 Mix of Isopropyl Alcohol (70%) and Water
Ratchet	Socket (10mm)	Socket (17mm)	Phillips Socket	Extension Bar	Sealant (Sikaflex-221)
Air Gun	Vacuum Cleaner	Torque Wrench	Spring Loaded Center Punch	Primer	Touch-Up Paint
Side Cutters	Masking Tape	Tape Measure			

Notes to the Installer :

- Read the entire installation pamphlet prior to beginning the installation of the accessory.
- Ensure that the vehicle is properly protected in the area that the accessory is to be installed.
- To prevent vehicle damage, never place tools on top of painted surfaces, seats, dash pad, console or floor carpet / mat.
- Always wear appropriate safety gear to include gloves and eye protection when required.
- Temperature of side step and vehicle must be between 60°F and 110°F prior to installation.





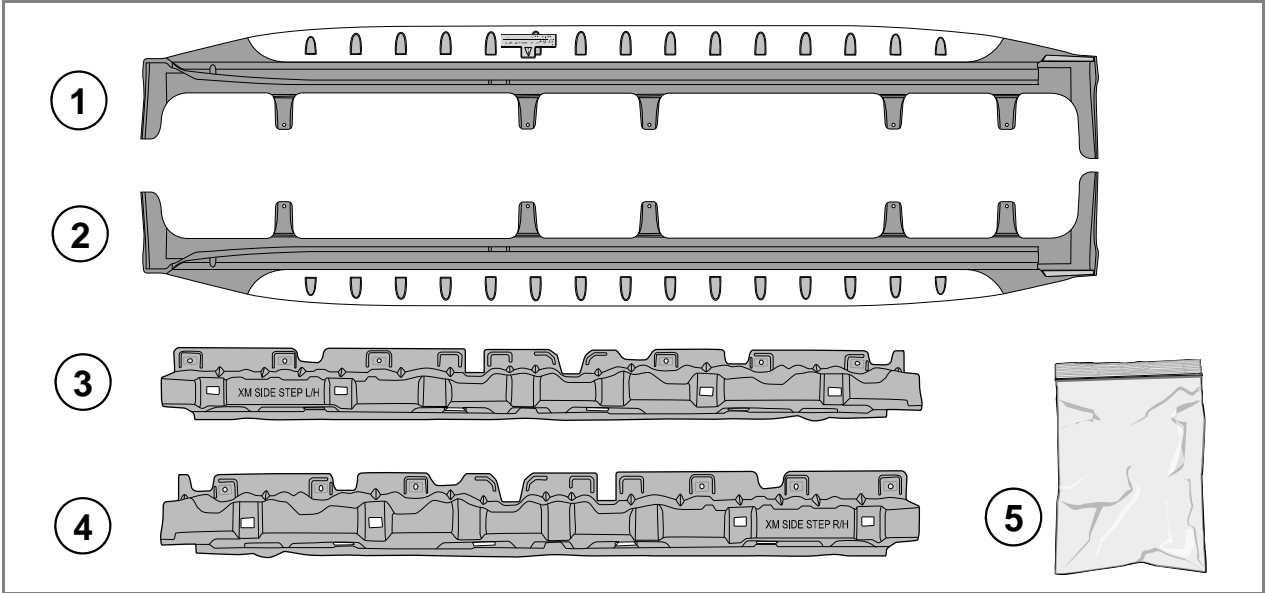



KIA Genuine Accessories

Kit Overview

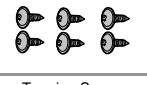

No.	Qty.	Description
1	1	SIDE STEP LH
2	1	SIDE STEP RH
3	1	ALUMINUM BRACKET (LH)
4	1	ALUMINUM BRACKET (RH)
5	1	HARDWARE BAG

Hardware Overview

A 	B 	C 	D 	E 
6 M10x25 T-Bolt	6 M10 Flange Nut	12 M6 Bolt	6 Tapping Screw	12 Fixing-Square Nut
F 	G 	H 	I 	
20 Blue Clip	2 Promoter	22 Film Pad	1 Instruction Sheet	

Hardware Kit Total
87

KIA Genuine Accessories

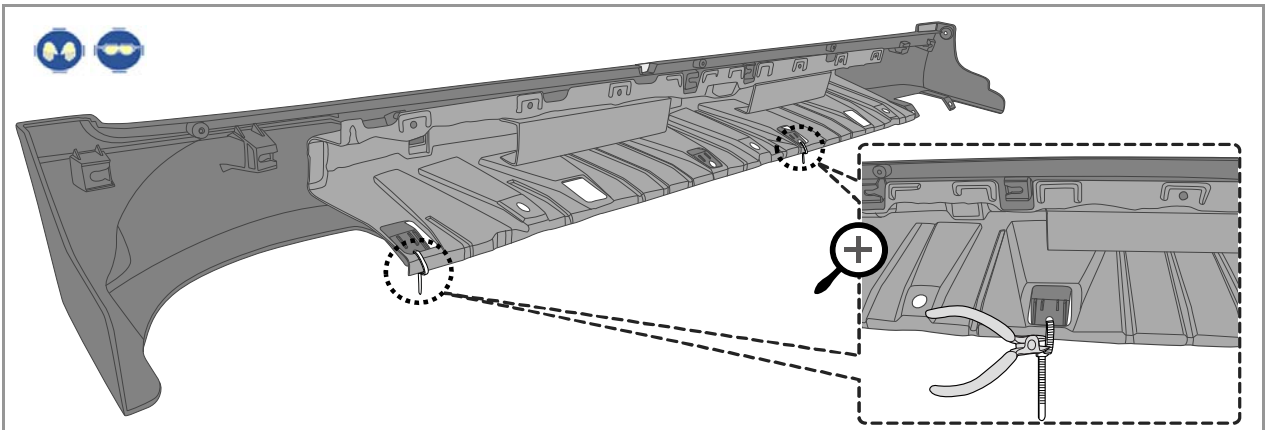

	Side Cutters	1
NOTE	<ol style="list-style-type: none"> Using side cutters, remove and discard the two (2) cable ties securing the aluminum bracket to the left (LH) side step as shown. Repeat the process on the right (RH) side step. 	

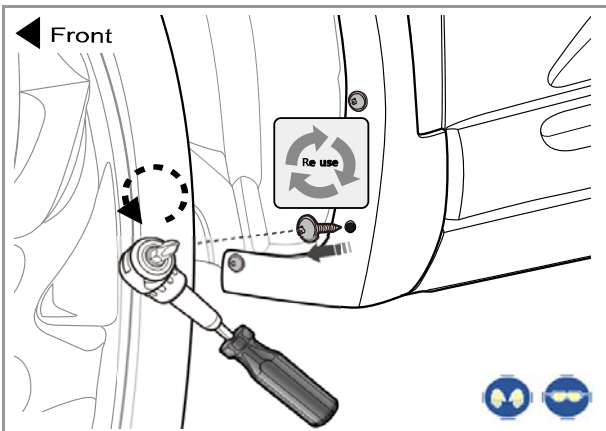

	Phillips Right Angle Driver	2
NOTE	<ol style="list-style-type: none"> Remove the one (1) screw from the LH front wheel well as shown. Keep the screw for reinstallation. 	

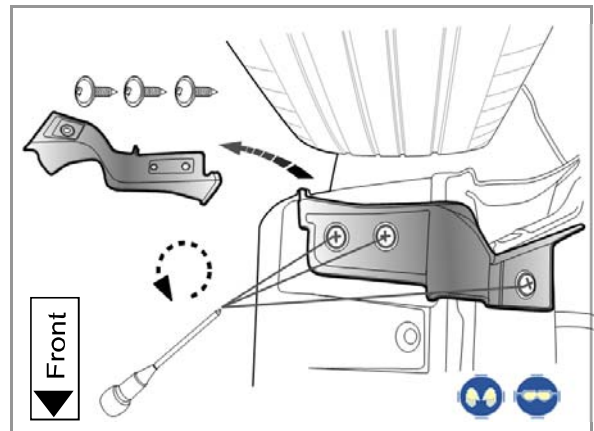

	Phillips Head Screwdriver	3
NOTE	<ol style="list-style-type: none"> Remove the three (3) screws from the front of the LH rear wheel well cover as shown (image is looking up under the vehicle). Remove the rear wheel well cover and discard it. Discard the screws. 	

KIA Genuine Accessories

	<p style="text-align: center;"> 4 </p> <p style="text-align: center;">Phillips Head Screwdriver</p>
NOTE	<ol style="list-style-type: none"> 1. Remove the eight (8) screws from under the LH side panel using a phillips head screwdriver. 2. Save five (5) of the screws previously removed and discard the remaining three (3).

	<p style="text-align: center;"> 5 </p> <p style="text-align: center;">Air Gun, Vacuum Cleaner, 50/50 mix of Isopropyl Alcohol (70%) and Water and Clean Cloth</p>
NOTE	<ol style="list-style-type: none"> 1. Remove the LH side panel by pulling it with your hands. 2. Remove the blue upper side panel clips from the vehicle by turning them 90° clockwise and pulling them out with your hands. Discard the clips. 3. Make sure to remove any remaining clip pieces from the vehicle by using an air gun and vacuum cleaner until the pieces are completely removed. 4. Clean the side panel with 50/50 mix of isopropyl alcohol (70%) and water as shown.
	<p>Ensure that the surface is clean and dry.</p>

	<p style="text-align: center;"> 6 </p> <p style="text-align: center;">Sealant</p>
NOTE	<ol style="list-style-type: none"> 1. Remove the nine (9) yellow clips from the lower LH side panel by turning them 90° clockwise and pulling them out with your hands. Save seven (7) of the yellow clips previously removed and discard the remaining two (2). 2. Attach two (2) film pads onto holes 3 and 6 as shown.
	<p>Ensure that the surface of holes 3 and 6 are clean and dry before attaching the film pad.</p>



	<p style="text-align: center;"> 7 </p> <p style="text-align: center;">Sealant</p>
NOTE	<ol style="list-style-type: none"> 1. Using two (2) yellow clips from step 6, apply sealant to the clips as shown. 2. Insert and attach two (2) yellow clips into holes 8 and 9 as shown.

KIA Genuine Accessories

◀ Front

		8
NOTE	1. Remove the three (3) factory installed hole caps from holes 2, 3, & 4 as shown.	

◀ Front

		9
NOTE	1. Insert three (3) M10x25 T-Bolts into the three (3) holes 2, 3 & 4 making sure to insert them in the direction as shown.	
	Make sure to install the T-Bolts in the direction as shown.	

◀ Front

		10
NOTE	1. Insert six (6) fixing-square nuts into the six (6) holes 3, 4, 5, 8, 9 & 10 of the vehicle making sure they're firmly seated as shown.	

KIA Genuine Accessories

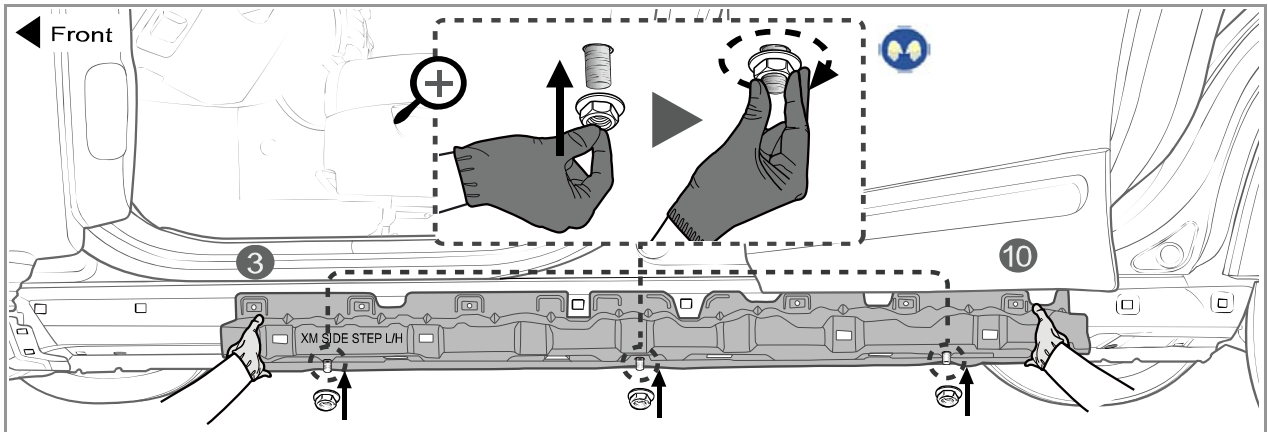

	11
NOTE	<p>1. Aligning the two (2) upper holes of the LH bracket to the fixing-square nuts inserted in holes 3 & 10, install the LH bracket over the three (3) M10x25 T-Bolts installed in step 9, then install & hand-tighten three (3) M10 flange nuts until the bracket holes are aligned with the side panel holes vertically in height as shown.</p>

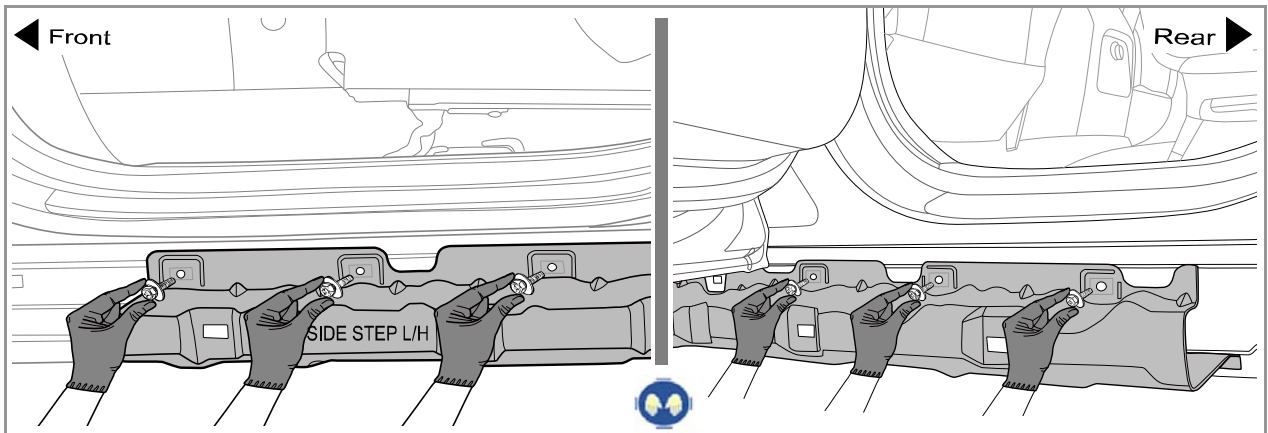

	12
NOTE	<p>1. Insert six (6) M6 bolts into the holes of the LH bracket from the left making sure that the bracket holes are properly aligned with the side panel holes.</p> <p>2. Hand-tighten the six (6) M6 bolts until there is no gap between the bolt and the bracket.</p>

KIA Genuine Accessories

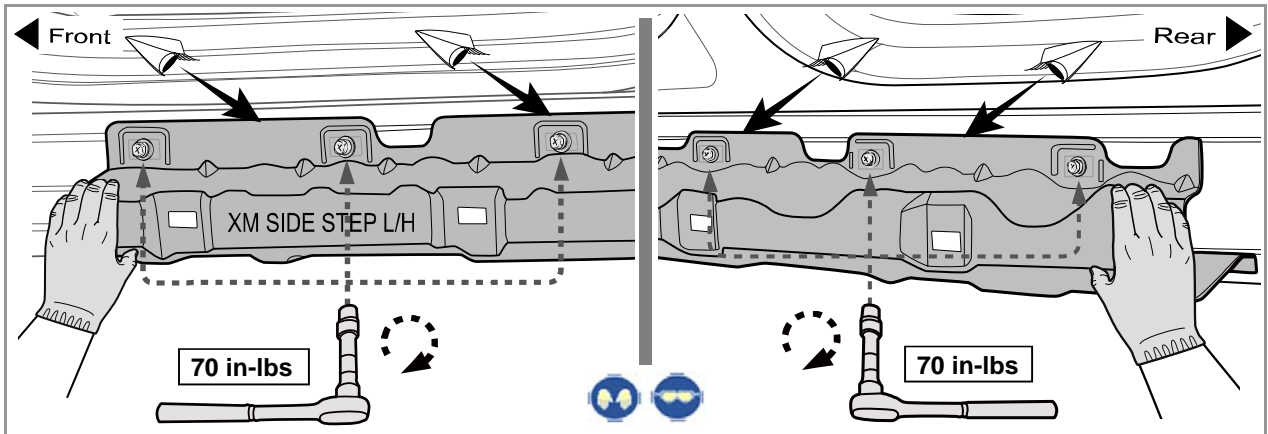

Ratchet, Socket (10mm) and Torque Wrench 13

- NOTE**
1. Press firmly on the bracket making sure there is no gap with the side panel, and starting from the left, tighten the six (6) M6 bolts at the upper part of the LH bracket as shown.
 2. Using a torque wrench, torque the six (6) M6 bolts to 70.0 in-lbs. Torque the bolts gently.

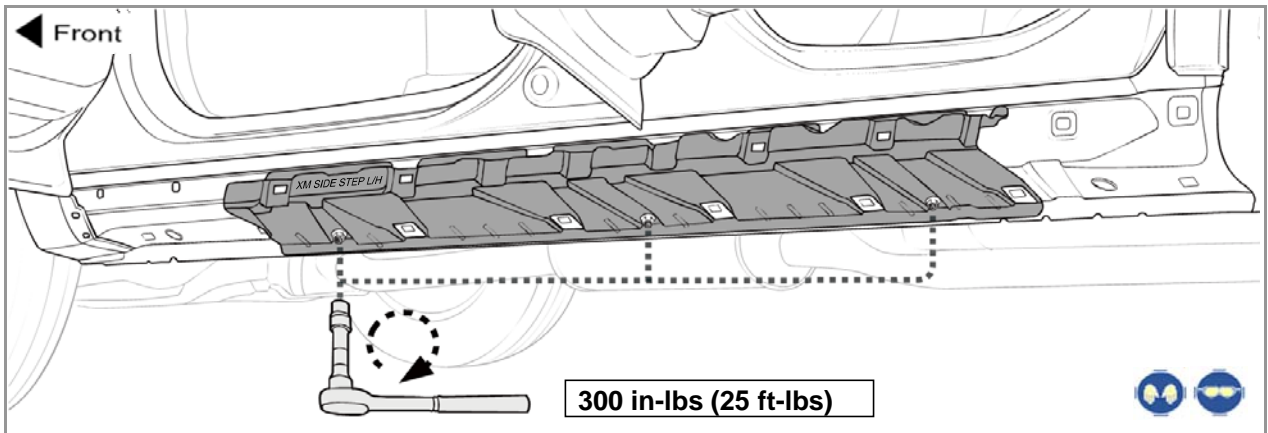

Ratchet, Socket (17mm) and Torque Wrench 14

- NOTE**
1. Tighten the three (3) M10x25 T-Bolts at the bottom part of the LH bracket using a 17mm socket.
 2. Torque the three (3) M10x25 T-Bolts to 300.0 in-lbs.

KIA Genuine Accessories

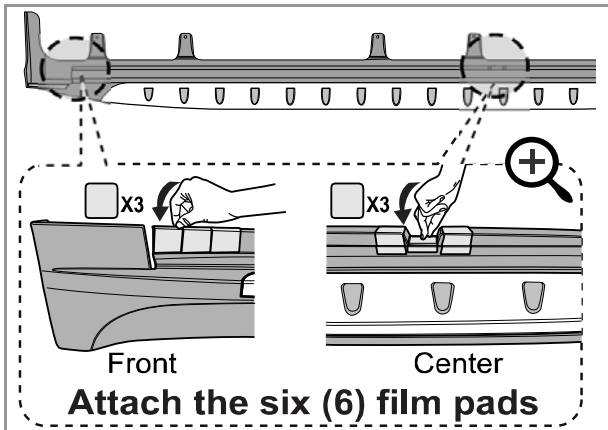

Attach the six (6) film pads



15

NOTE

1. Attach six (6) film pads onto the areas of the LH side step as shown.

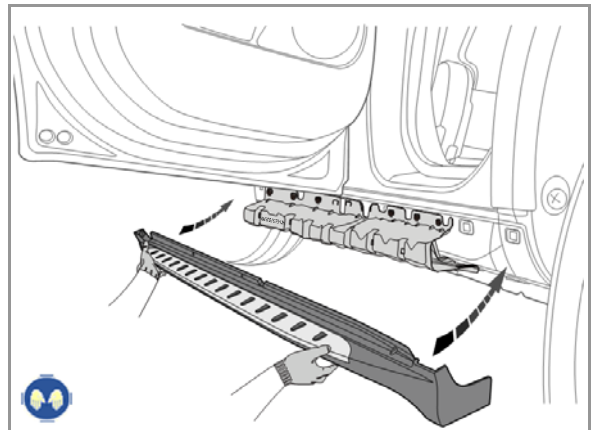

16

NOTE

1. Temporarily place the LH side step on the vehicle.
2. Make sure the LH side step is properly aligned.



Be careful not to damage the side step while installing.

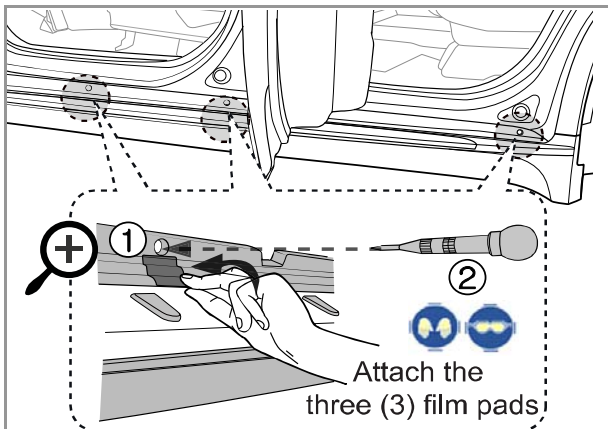

Attach the three (3) film pads



Spring Loaded Center Punch

17

NOTE

1. Attach three (3) film pads to the area just below the three (3) holes located on the side step as shown.
2. Mark the holes using a spring loaded center punch.

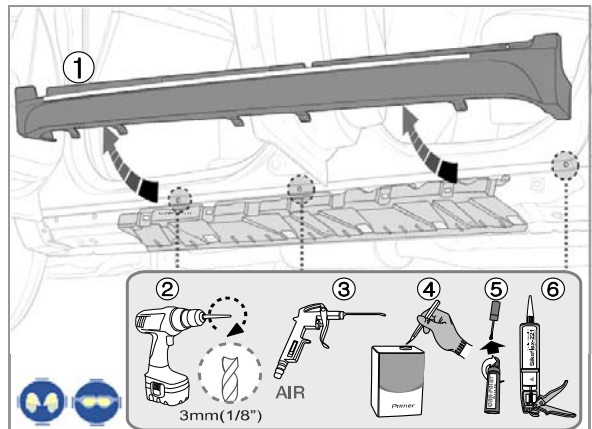

Power Drill, Drill Bit (3mm, 1/8"), Air Gun, Primer, Touch-Up Paint and Sealant

18

NOTE

1. Remove the side step.
2. Drill three (3) holes using a drill bit (3mm, 1/8").
3. Use an air gun to remove all residue and burs.
4. Apply primer to the drilled holes. Make sure that the primer is completely dried before proceeding to the next step.
5. Apply touch-up paint to the drilled holes as a corrosion shield and then apply sealant to each hole.



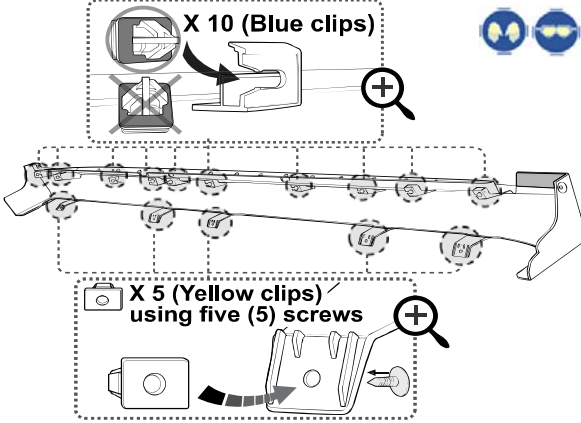

Touch-up paint required to prevent future corrosion concerns.

KIA Genuine Accessories

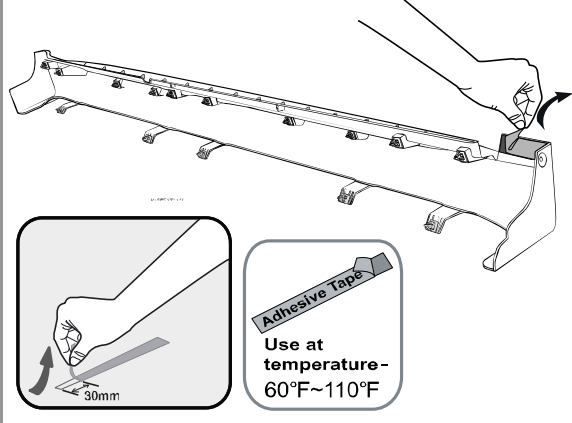

	Phillips Head Screwdriver	19
N O T E	<ol style="list-style-type: none"> 1. Install ten (10) provided blue clips onto the side step and make sure the clips are inserted in the proper direction as shown. 2. Using five (5) screws from step 4, install the yellow clips removed in step 6 onto the side step as shown. 	



	Masking Tape	20
N O T E	<ol style="list-style-type: none"> 1. Slightly peel away 30mm of the backing from the adhesive tape on the front side of the side step. Use masking tape to hold the backing to the front of the side step. 	
		Be careful to not touch or contaminate the surface of the adhesive tape.

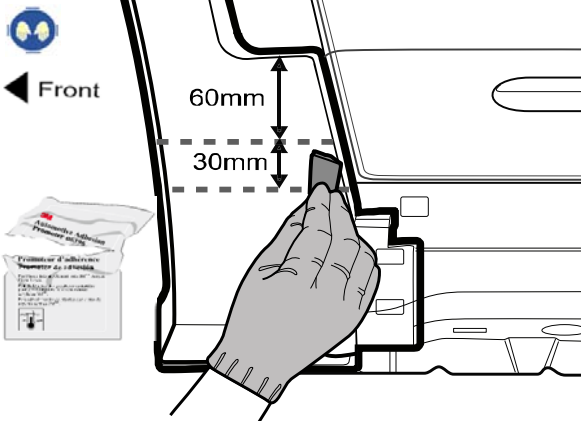

	Tape Measure and Masking Tape	21
N O T E	<ol style="list-style-type: none"> 1. Apply promoter to the LH front fender about 60mm below the top edge. Use masking tape if necessary to mark the reference line. 	
		<p>Make sure the promoter does not contact any other part or area of the front fender or door. Promoter may cause skin irritation if it is contacted with bare skin.</p>

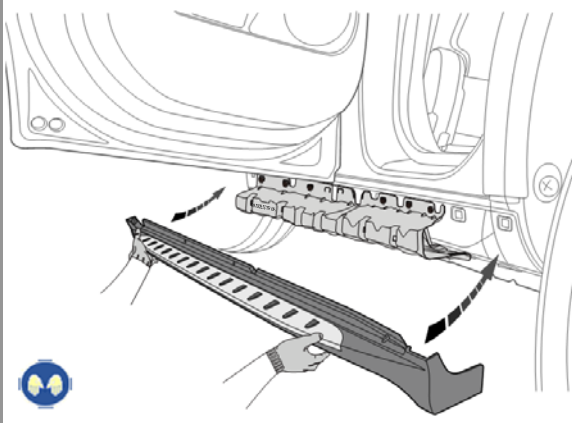

		22
N O T E	<ol style="list-style-type: none"> 1. Open the front and rear doors and carefully place the side step onto the LH bracket. 	

KIA Genuine Accessories

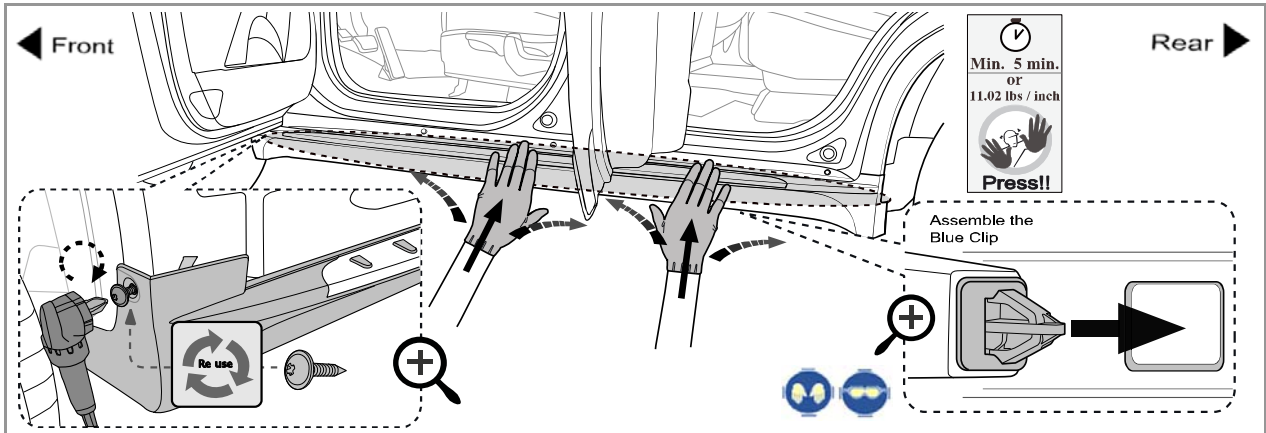

Phillips Right Angle Driver 23

NOTE

1. Align and insert ten (10) provided blue clips from the LH side step into the LH bracket and vehicle holes as shown. Make sure there is an audible click from each blue clip to confirm installation.
2. Temporarily insert the screw removed in step 2 through the side step and hole located in the front wheel well as shown.
3. Press firmly on the surface of the side step with a pressure of 11.02 lbs / inch or minimum of 5 minutes to ensure a solid attachment.

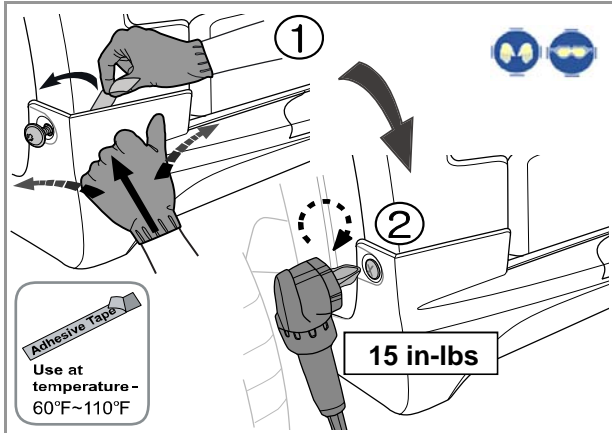

Phillips Right Angle Driver, Phillips Socket and Torque Wrench 24

NOTE

1. Completely peel away the backing from the adhesive tape on the front end of the side step.
2. Apply pressure to the front end of the side step, into the wheel arch garnish, to ensure a solid attachment.
3. Fasten the screw installed in step 23 while pushing the side step inward. Torque the screw to 15.0 in-lbs.

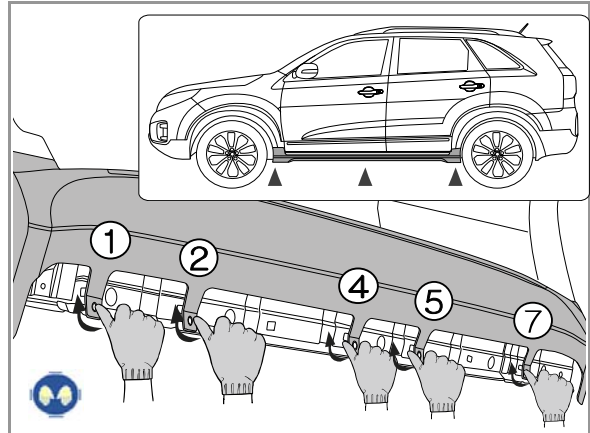

25

NOTE

1. Using your thumbs, insert the five (5) yellow clips through the lower side panel of the vehicle as shown above. Make sure there is an audible click from each yellow clip to confirm installation.

KIA Genuine Accessories

Remove the nine(9) film pads

25 in-lbs ①

X 3EA

Front Rear

	Phillips Head Screwdriver, Phillips Socket and Torque Wrench	26
NOTE	<ol style="list-style-type: none"> 1. Fasten three (3) steel tapping screws into the drilled holes as shown. Torque the screws to 25 in-lbs. 2. Remove the nine (9) film pads attached in steps 15 & 17 and discard. 3. Repeat steps 1-26 for the right (RH) side of the vehicle. 4. Installation is complete. 	
	<p>Recommendation</p> <ul style="list-style-type: none"> * Do not drive the vehicle at high speed (no more than 60mph) within 24 hours after installation. * Do not use machine car wash within 8 hours after installation. * Avoid using an alkaline type detergent on the side steps as the anodized surface may change color. 	